

Varispeed-616G3

INSTRUCTIONS

SUPER LOW-NOISE GENERAL-PURPOSE INVERTER

200 to 230V, 40 to 100HP (30 to 75kW) 54 to 130kVA
380 to 460V, 75 to 200HP (55 to 160kW) 110 to 250kVA



Before initial operation, read these instructions thoroughly,
and retain for future reference



YASKAWA



UL Listed



CSA Certified

TOA-S616-6.5B

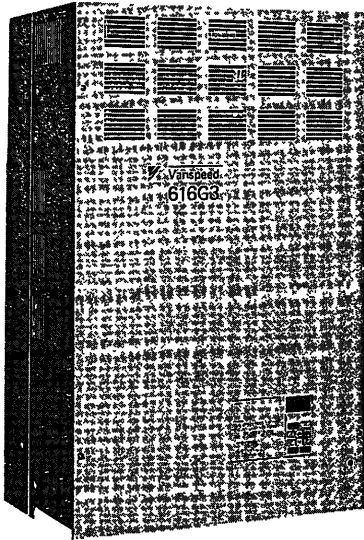

94 C71 002

An inverter is a device which converts three-phase AC commercial power supply to DC with an inverter section, producing AC variable frequency voltage from this converted DC.

This AC variable frequency voltage can then be used for speed control of three-phase squirrel-cage induction motors.

WARNING

- 1) After turning OFF the main circuit power supply, do not touch circuit components until "CHARGE" lamp is extinguished. The capacitors are still charged and can be quite dangerous.
- 2) Do not connect or disconnect wires and connectors while power is applied to the circuit.
- 3) Do not check signals during operation.
- 4) Be sure to ground VS-616G3 using the ground terminal G (E).
- 5) Never connect main circuit output terminals T1 (U), T2 (V), T3 (W) to AC main circuit power supply.

CAUTION

- 1) All the constants of VS-616G3 have been adjusted at the factory. Do not change their settings unnecessarily.
- 2) Do not perform any dielectric tests on any part of the VS-616G3 unit. The VS-616G3 contains semi-conductor devices and is vulnerable to damage from high voltage.
- 3) The control PC board employs CMOS ICs which are easily damaged by static electricity. Do not touch the CMOS elements.
- 4) Make sure to tighten screws on the main circuit and control circuit terminals.

CONTENTS

VS-616G3 CONFIGURATION	5
RECEIVING	6
INSTALLATION	7
MOUNTING SPACE	7
LOCATION	8
WIRING	9
CONNECTION DIAGRAM	9
MAIN CIRCUIT	10
CONTROL CIRCUIT	15
INITIAL OPERATION	17
CHECKS BEFORE INITIAL OPERATION	17
SETTING THE LINE VOLTAGE USING JUMPER (FOR 460V CLASS)	17
OPERATION	18
DIGITAL OPERATOR	18
DRIVE MODE AND PRGM MODE	19
BASIC CONSTANTS	22
INPUT VOLTAGE SETTING	23
DIGITAL OPERATOR OPERATION	24
CONTROL TERMINAL OPERATION	26
MAINTENANCE	27
PERIODIC INSPECTION	27
FAULT DISPLAY	28

CONTENTS (APPENDIX)

A SPECIFICATIONS	30
B DIMENSIONS in inches (mm)	31
C V/f PATTERN (Sn-02)	32
D TYPICAL CONNECTION DIAGRAM	34
(1) Braking Unit (3 in parallel)	34
(2) Run/Stop by Main Circuit Magnetic Contactor for Model CIMR-G3A2L30	36
(3) With VS Operator Model JVOP-95•□	37
(4) With VS Operator Model JVOP-96•□	38
(5) With Transistor Open Collector for Operation Signal	39
(6) With Contact Output, Photo-coupler Output	40
E OPTIONS	41
(1) OPTION CARDS	41
(2) OPTION UNITS	43

VS-616G3 CONFIGURATION

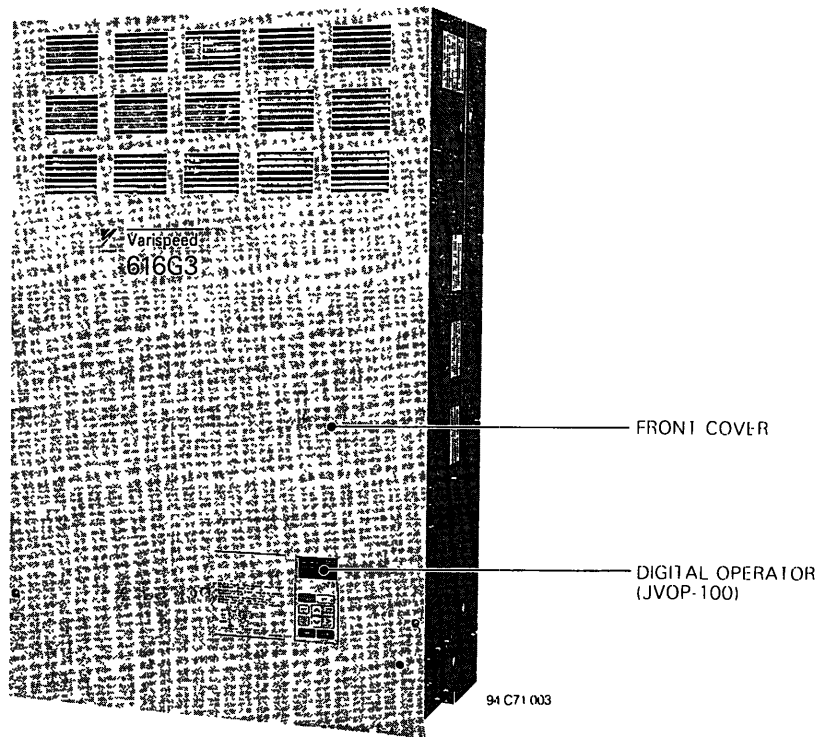

VS-616G3

RECEIVING

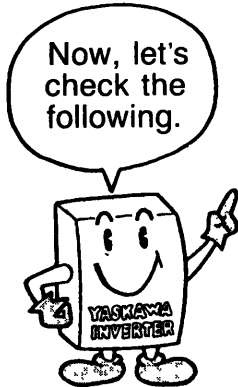

This VS-616G3 has been put through demanding tests at the factory before shipment. After unpacking, check the following:

- Verify that the received product matches the purchase order sheet (invoice) and/or packing slip.
- Transit damage.

If any part of the VS-616G3 is damaged or missing, immediately notify the shipper.

NAMEPLATE DATA

MODEL: CIMR-G3U2L30		SPEC: 2L300	
A.C. INPUT		A.C. OUTPUT	
VOLTS: 200-220	HZ: 50	VOLTS: 0-230 MAX.	HZ: 0-400 PHASE: 3
VOLTS: 200-230	HZ: 60	VARIABLE TORQUE CONT.	AMPS: 146.0 HP: 50
PHASE: 3	AMPS: 160.0	CONSTANT TORQUE CONT.	AMPS: 130.0 HP: 40
FILE NO. : E131457			

Design
Revision
Order

Enclosure

- 0* : Open Chassis Type
 - 1 : NEMA1 (Enclosed wall-mounted Type)
- * Blank in SPEC without design revision order

MODEL DESIGNATION

CIMR - G3 U 2 L 30

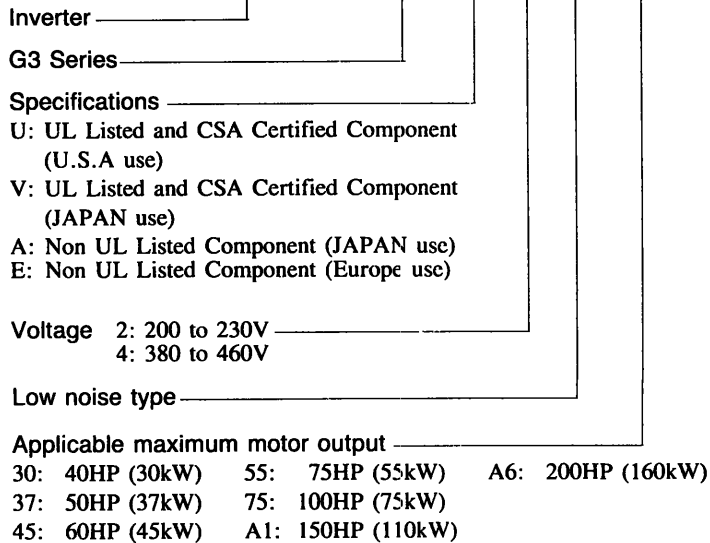

INSTALLATION

CAUTION

- Never move, lift or handle the VS-616G3 cabinet by the front cover.
- Lift the cabinet from the bottom.
- Do not drop the inverter.

MOUNTING SPACE

Install the VS-616G3 vertically and allow sufficient space for effective cooling as shown in Fig. 1.

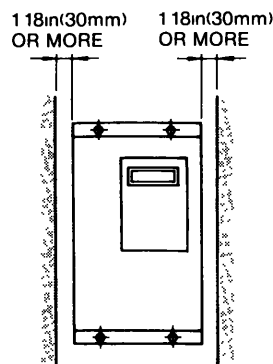
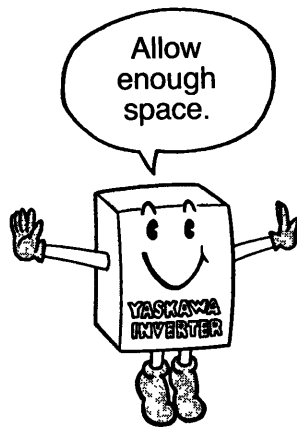

(a) Front View

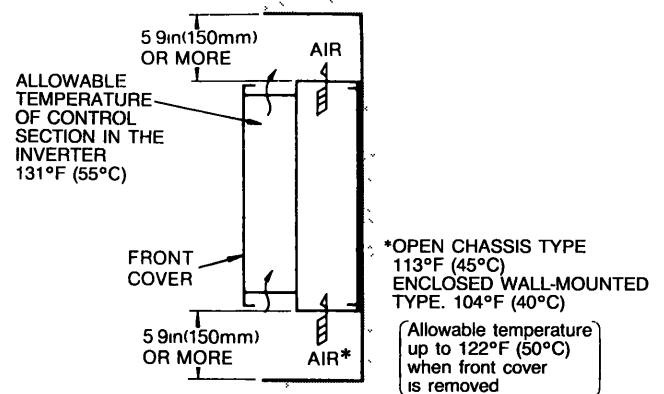

(b) Side View

Note: For product external and mounting dimensions, refer to APPENDIX B "DIMENSIONS" on page 31.

Fig. 1 Minimum Mounting Space

LOCATION

Location of the VS-616G3 is important in achieving proper performance and normal operating life. The VS-616G3 should be installed in an area where the following conditions exist:

- Protection from rain or moisture.
- Protection from direct sunlight.
- Protection from corrosive gases or liquids.
- Free from airborne dust or metallic particles.
- Free from vibration.
- Free from magnetic noise (e.g. welding machines, power units)
- Ambient temperature:
 - + 14 to 104°F, - 10 to +40°C (For enclosed type),
 - + 14 to 113°F, - 10 to +45°C (For open chassis type)
- Free from combustible materials, gases, etc.

CAUTION

When mounting units in a common enclosure, install a cooling fan or use some other method to keep the air entering the inverter below 113°F (45°C).

WIRING CONNECTION DIAGRAM

The following shows an interconnection diagram of the main circuit and control circuit. With the digital operator, the motor can be operated by wiring the main circuit only.

- ⊙: Main circuit
- : Control circuit

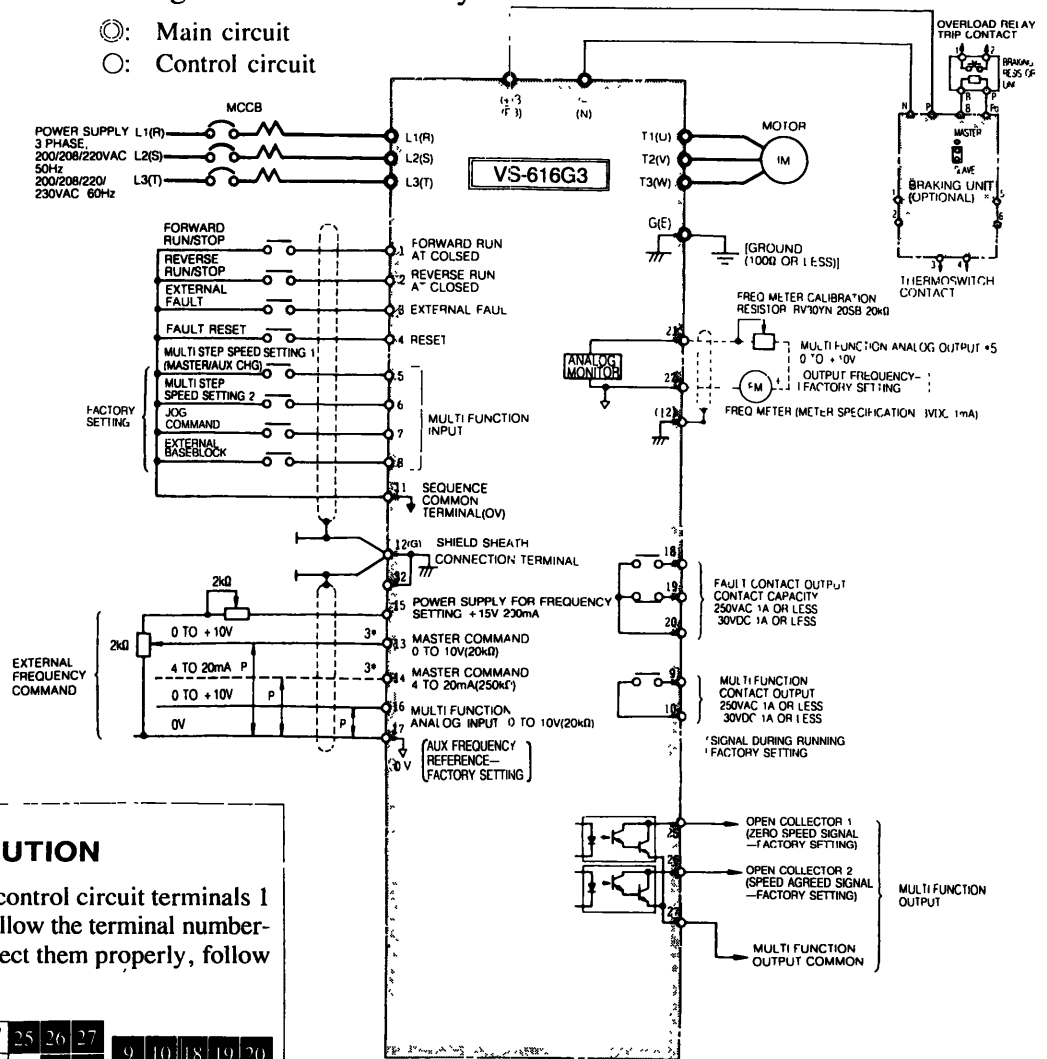

CAUTION

The connections of control circuit terminals 1 through 27 do not follow the terminal numbering order. To connect them properly, follow the figure below.

11	(G) 12	13	14	15	16	17	25	26	27	9	10	18	19	20
1	2	3	4	5	6	7	8	21	22					

IMPORTANT

Use UL Listed and CSA Certified closed-loop (ring) connectors sized for the wire gauge involved. Connectors should be installed using the correct crimp tool specified by the connector manufacturer.

Notes:

1. indicates shielded leads and indicates twisted-pair shielded leads.
2. Control circuit terminal 15 of +15V has a maximum output current capacity of 20mA.
3. Either external terminal 13 or 14 can be used. (For simultaneous inputs, the two signals are added internally.)
4. Multi-function analog output should be used for monitoring meters such as an output frequency meter and should not be used for the feedback control system. Use analog monitor cards (Model AO-08 or AO-12) for the control system.

Fig. 2 Connection Diagram

MAIN CIRCUIT

MAIN CIRCUIT TERMINALS

Model CIMR-G3	2L30 to 2L75	4L55 to 4LA6
Max Applicable Motor Output	230V Class 40 to 100HP (30 to 75kW)	460V Class 75 to 200HP (55 to 160kW)
Terminals		
L1 (R)	Main circuit input power supply	
L2 (S)		
L3 (T)		
T1 (U)		
T2 (V)	Inverter output	
T3 (W)		
⊖ (N)		
⊕ 3 (P3)	<ul style="list-style-type: none"> • Braking resistor unit (⊕3-⊖) • Main circuit capacitor (⊕3-⊖) 	
ℓ ₁ (r)	• Cooling fan power supply (control power supply)	• Cooling fan power supply (control power supply)
ℓ ₂ (Δ)	ℓ ₁ -ℓ ₂ 200 to 230VAC input	ℓ ₁ -ℓ ₂ 200 200 to 230VAC input
ℓ ₂ 200 (Δ200)		ℓ ₁ -ℓ ₂ 400 380 to 460VAC input
ℓ ₂ 400 (Δ400)		
x		• External power supply (220VAC, 10VA)
y		
G (E)	Ground terminal	

■ Model CIMR-G3 2L30 to 2L75

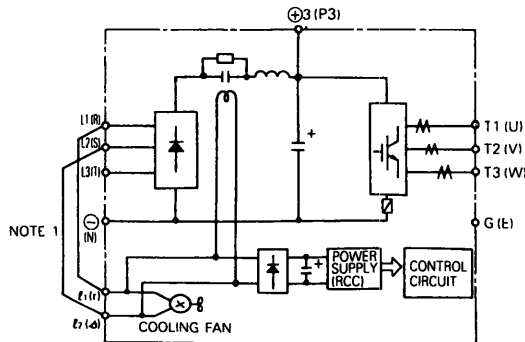

■ Model CIMR-G3 4L55 to 4LA6

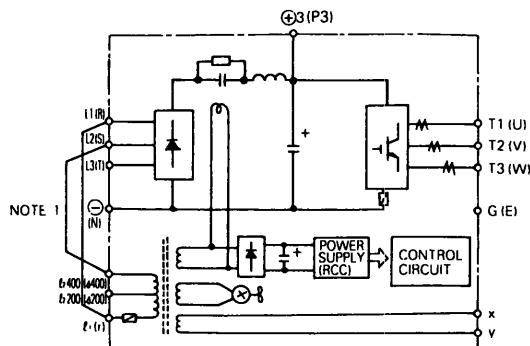

- Notes:
1. When the main circuit and control circuit power supplies are separately provided, remove the control circuit jumper. If not provided separately, never remove the wiring to the control circuit.
 2. RCC power supply is provided from the control power supply circuit.

MOLDED-CASE CIRCUIT BREAKER (MCCB) AND FUSE FOR BRANCH CIRCUIT PROTECTION

Be sure to connect MCCB's or fuses between the AC main circuit power supply and VS-616G3 input terminals L1 (R), L2 (S) and, L3 (T) to protect the wiring. Recommended ratings of MCCB and fuses are listed in Table 1. The fuses should be class RK5 fuses.

When a ground fault interrupter is used, select one with no influence for high frequency. In order to prevent malfunction, setting current should be 200 mA or above, and operating time should be 0.1 sec or longer.

- (Example)
- Mitsubishi Electric NV series (manufactured in 1988 and after)
 - Fuji Electric EGSG series (manufactured in 1984 and after)

Table 1 Branch Circuit Protection

230V Class

VS-616G3	Model CIMR-	200 to 230V					
		G3L3L30	G3L3L37	G3L3L45	G3L3L55	G3L3L75	
	Capacity	kVA	54	68	78	95	130
	Rated Output Current	A	130	160	183	224	300
MCCB or Fuse, Class RK5	Rated Current		225A	225A	300A	400A	600A

460V Class

VS-616G3	Model CIMR-	380 to 460V				
		G3L4L55	G3L4L75	G3L4LA1	G3L4LA6	
	Capacity	kVA	110	140	200	250
	Rated Output Current	A	128	165	224	300
MCCB or Fuse, Class RK5	Rated Current		225A	300A	400A	600A

SURGE SUPPRESSOR

Surge suppressors should be connected to the coils of relays, magnetic contactors, magnetic valves, or magnetic relays. See Table 2.

Table 2 Surge Suppressors

Coils of Magnetic Contactor and Control Relay		Surge Suppressor*		
		Model	Specifications	Yaskawa Code No.
200 to 230V	Large-sized Magnetic Contactors	DCR2-50A22E	250 VAC 0.5μF + 200Ω	C002417
	Control Relays MY-2, -3(OMRON) HH-22, -23(Fuji) MM-2, -4(OMRON)	DCR2-10A25C	250 VAC 0.1μF + 100Ω	C002482
380 to 460V Units		DCR2-50D100B	1000 VDC 0.5μF + 220Ω	C002630

*Made by MARCON Electronics

WIRE AND TERMINAL SCREW SIZES

- Wire sizes and types are shown in Tables 3 and 4.
- Use 75°C copper wires only.
- Low voltage terminals shall be wired with Class I Wiring.

Table 3 230V Class Wire Size

Circuit	VS-616G3 Model CIMR-	Inverter Capacity kVA	Terminal		75°C Wire Range		Wire Type
			Symbol	Screw	AWG	mm ²	
Main Circuit	G3: 2L30 [†]	54	L1 (R), L2 (S), L3 (T), ⊖ (N), ⊕3 (P3), T1 (U), T2 (V), T3 (W)	M 10	3 / 0	86	Power cable 600V vinyl sheathed wire or equivalent
			G (E)	*	4 - 2	22 - 34	
			ℓ1 (r), ℓ2 (s)	M 4	14 - 10	2 - 5.5	
	G3: 2L37 [†]	68	L1 (R), L2 (S), L3 (T), ⊖ (N), ⊕3 (P3), T1 (U), T2 (V), T3 (W)	M 10	1/0×2P	54×2P	
			G (E)	*	4 - 2	22 - 34	
			ℓ1 (r), ℓ2 (s)	M 4	14 - 10	2 - 5.5	
	G3: 2L45 [†]	78	L1 (R), L2 (S), L3 (T), ⊖ (N), ⊕3 (P3), T1 (U), T2 (V), T3 (W)	M 10	2/0×2P	68×2P	
			G (E)	*	4 - 2	22 - 34	
			ℓ1 (r), ℓ2 (s)	M 4	14 - 10	2 - 5.5	
	G3: 2L55 [†]	95	L1 (R), L2 (S), L3 (T), ⊖ (N), ⊕3 (P3), T1 (U), T2 (V), T3 (W)	M 10	4/0×2P	108×2P	
			G (E)	*	3 - 2	27 - 38	
			ℓ1 (r), ℓ2 (s)	M 4	14 - 10	2 - 5.5	
	G3: 2L75 [†]	130	L1 (R), L2 (S), L3 (T), ⊖ (N), ⊕3 (P3), T1 (U), T2 (V), T3 (W)	M 12	300CM×2P	152×2P	
			G (E)	*	1 - 2/0	43 - 68	
			ℓ1 (r), ℓ2 (s)	M 4	14 - 10	2 - 5.5	
Control Circuit	Common to All Models	—	1 - 27	M 3.5	18 - 14	0.75 - 2	Twisted shielded wire with class I wiring or equivalent.

* Indicates the use of Pressure Lug Terminals.

† □ indicates "U" or "V".

Table 4 460V Class Wire Size

Circuit	VS-616G3 Model CIMR-	Inverter Capacity kVA	Terminal		75°C Wire Range		Wire Type
			Symbol	Screw	AWG	mm ²	
Main Circuit	G3: 34LS5†	110	L1 (R), L2 (S), L3 (T), ⊖ (N), ⊕1 (P3), T1 (U), T2 (V), T3 (W)	M 10	4 - 2	22 - 34	Power cable: 600V vinyl sheathed wire or equivalent
			G (E)	*	14 - 10	2 - 5.5	
			ℓ1 (r), ℓ2 200 (♂200), ℓ2 400 (♂400), x, y	M 4	1/0 × 2P	54 × 2P	
	G3: 34L75†	140	L1 (R), L2 (S), L3 (T), ⊖ (N), ⊕1 (P3), T1 (U), T2 (V), T3 (W)	M 10	4 - 2	22 - 34	
			G (E)	*	14 - 10	2 - 5.5	
			ℓ1 (r), ℓ2 200 (♂200), ℓ2 400 (♂400), x, y	M 4	4/0 × 2P	108 × 2P	
	G3: 34LA1†	200	L1 (R), L2 (S), L3 (T), ⊖ (N), ⊕1 (P3), T1 (U), T2 (V), T3 (W)	M 10	3 - 2	27 - 34	
			G (E)	*	14 - 10	2 - 5.5	
			ℓ1 (r), ℓ2 200 (♂200), ℓ2 400 (♂400), x, y	M 4	250MCM × 2P	127 × 2P	
	G3: 34LA6†	250	L1 (R), L2 (S), L3 (T), ⊖ (N), ⊕1 (P3), T1 (U), T2 (V), T3 (W)	M 12	1 - 2/0	43 - 68	
			G (E)	*	14 - 10	2 - 5.5	
			ℓ1 (r), ℓ2 200 (♂200), ℓ2 400 (♂400), x, y	M 4	350MCM × 2P	177 × 2P	
Control Circuit	Common to All Models	—	1 - 27	M 3.5	18 - 14	0.75 - 2	Twisted shielded wire with class 1 wiring or equivalent.

* Indicates the use of Pressure Lug Terminals.

† [] indicates "U" or "V".

IMPORTANT

When determining wire sizing, voltage drop should be considered. Select the wire size so that voltage drop will be less than 2% of the normal rated voltage. Voltage drop is obtained by the following equation.

$$\text{Phase-to-phase voltage drop (V)} = \sqrt{3} \text{ wire resistance } (\Omega/\text{km}) \times \text{wiring distance (m)} \times \text{current (A)} \times 10^{-3}$$

CAUTION

The external interconnection wiring must be performed with following procedures.

After completing VS-616G3 interconnections, be sure to check that connections are correct. Never use control circuit buzzer check.

MAIN CIRCUIT INPUT/OUTPUT

- (1) Phase rotation of input terminals L1 (R), L2 (S), L3 (T) has no effect on motor rotation.
- (2) To reverse motor rotation, interchange any two of the motor leads.
- (3) Never connect the AC main circuit power supply to output terminals T1 (U), T2 (V), or T3 (W). Inverter damage may occur.
- (4) Care should be taken to prevent contact of wiring leads with VS-616G3 cabinet, for short-circuit may result.
- (5) Never connect power factor correction capacitors to VS-616G3 output.
- (6) Never open or close contactors in the output circuit unless the inverter is properly sized.

GROUNDING

Ground the casing of the VS-616G3 using ground terminal G (E).

- (1) Ground resistance should be 100Ω or less.
- (2) Never ground the VS-616G3 in common with welding machines, motors, and other large-current electrical equipment. Run the ground lead in a separate conduit from leads of large-current electrical equipment.
- (3) Use ground leads which comply with AWG standards using the shortest length possible.
- (4) When several VS-616G3 units are used side by side, all the units should preferably be grounded directly to the ground poles. However, connecting the ground terminal of VS-616G3 units in parallel, and grounding only one of the VS-616G3 units to the ground pole is also permissible (Fig. 3). However, do not form a loop with the ground leads.

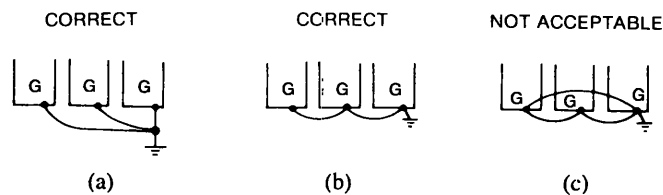

Fig. 3 Grounding of Three VS-616G3 Units

CONTROL CIRCUIT

Low voltage terminals shall be wired with Class I Wiring.

CONTROL CIRCUIT TERMINALS

Classification	Terminal	Signal Function	Description	Signal Level	
Sequence Input Signal	1	Forward operation-stop signal	Forward run at closed, stop at open	Photo-coupler insulation Input + 24VDC 8mA	
	2	Reverse operation-stop signal	Reverse run at closed, stop at open		
	3	External fault input	Fault at closed, normal state at open		
	4	Fault reset input	Reset at closed		
	5	Master/Aux. change (Multi-step speed ref.1)	Aux. freq. ref. at "closed"		Multi-function contact inputs: Forward/reverse, run mode, multi-speed, jog frequency, accel/decel time, external fault, external base block stop, hold command, inverter overheat prediction, DB command, aux. input effective, speed search, energy-saving operation
	6	Multi-step speed ref.2	Effective at "closed"		
	7	Jog command	Jog run at "closed"		
	8	External coasting stop	Inv. output stop at "closed"		
		11	Sequence control input common terminal		—
Analog Input Signal	15	Power supply terminal for speed ref.	Speed ref. power supply	+ 15V (Allowable current 20mA max.)	
	13	Master speed frequency ref.	0 to +10V/100% freq.	0 to +10V (20kΩ)	
	14		4 to 20mA/100% freq.	4 to 20mA (250Ω)	
	16	Aux. frequency ref.	10V/100%	Multi-function analog input: Speed command, speed gain, speed bias, overtorque, overvoltage bias, rate of accel / decel DB current	0 to +10V (10kΩ)
	17	Common terminal for control circuit	0V	—	
	12	Connection to shield sheath of signal lead	—	—	
Sequence Output Signal	9	During running (NO)	"Closed" when running	Multi-function contact outputs: Output during running, zero speed, agreed speed, arbitrary agreed speed, frequency detection, overtorque, undervoltage, run mode, coasting stop, braking resistor overheat	Dry contact Contact capacity: 250VAC 1A or less 30VDC 1A or less
	10				
	25	Zero speed detection	Makes at min, freq. (Cn-07) or less	Open collector output +48V 50mA or less	
	26	Speed agreed detection	Makes when the freq. reaches to ±1% of set freq.		
	27	Open collector output common			—
	18	Fault contact output (NO, NC)	Fault at closed between terminals 18 and 20		Dry contact Contact capacity: 250VAC 1A or less 30VDC 1A or less
	19		Fault at open between terminals 19 and 20		
20					
Analog Output Signal	21	Frequency meter output	0 to 10V/100% freq.	Multi-function analog output: frequency, current, voltage, and kilowatt meter selection available.	0 to 11V max. 2mA or less
	22	Common			

■ TYPICAL CONTROL CIRCUIT TERMINAL ARRANGEMENT

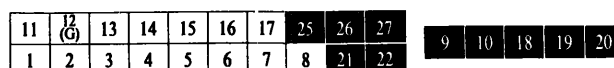

CAUTION

External interconnection wiring should be performed using the following procedures.

After completion, be sure to check that connections are correct. Never use a control circuit buzzer check.

(1) Separation of control circuit leads and main circuit leads

Signal leads 1 through 32 must be separated from main circuit leads L1 (R), L2 (S), L3 (T), \oplus 3 (P3), T1 (U), T2 (V), T3 (W), \ominus (N) and other power cables to prevent erroneous operation caused by noise interference.

(2) Control circuit leads 9, 10, 18, 19, 20 (contact output) must be separated from leads 1 to 8, 11 to 17, 21, 22 and 25 to 27.

(3) Use twisted shielded or twisted-pair shielded wire for the control circuit line and connect the shield sheath to the inverter terminal 12. See Fig. 4. Wiring distance should be less than 164 ft (50 m).

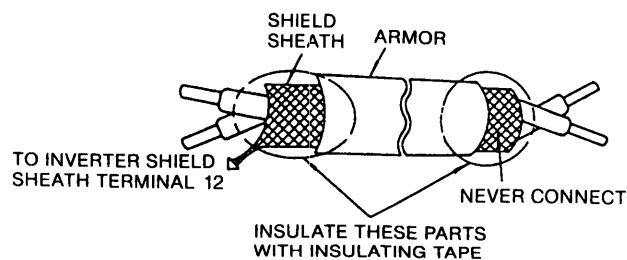

Fig. 4 Shielded Wire Termination

INITIAL OPERATION

To assure safety, prior to initial operation, disconnect the machine coupling so that the motor is isolated from the machine. If initial operation must be performed while the motor is still coupled to the machine, use great care to avoid potentially hazardous conditions.

CHECKS BEFORE INITIAL OPERATION

After completion of installation and wiring, check for:

- (1) proper wiring and terminal connections
- (2) wire clippings that could cause short circuit
- (3) screw-type terminals are tightened
- (4) proper load

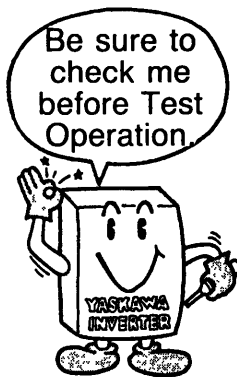

SETTING THE LINE VOLTAGE USING JUMPER

(FOR 460V CLASS)

The line voltage jumper shown in Fig. 5 must be set according to the main circuit power supply. Insert the jumper at the appropriate location corresponding to the input line voltage. It has been preset at the factory at 460V.

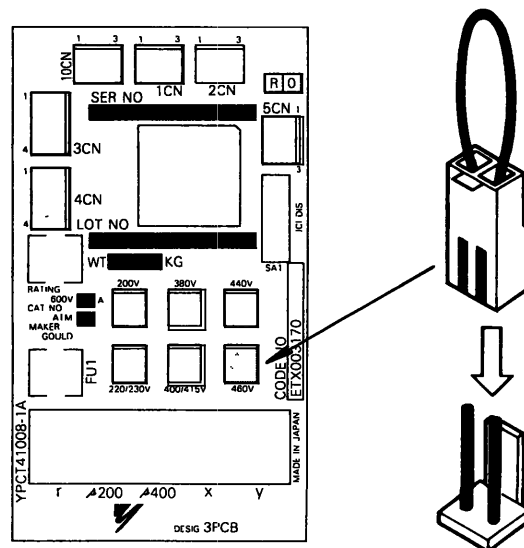

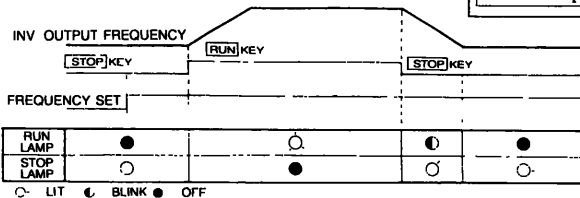
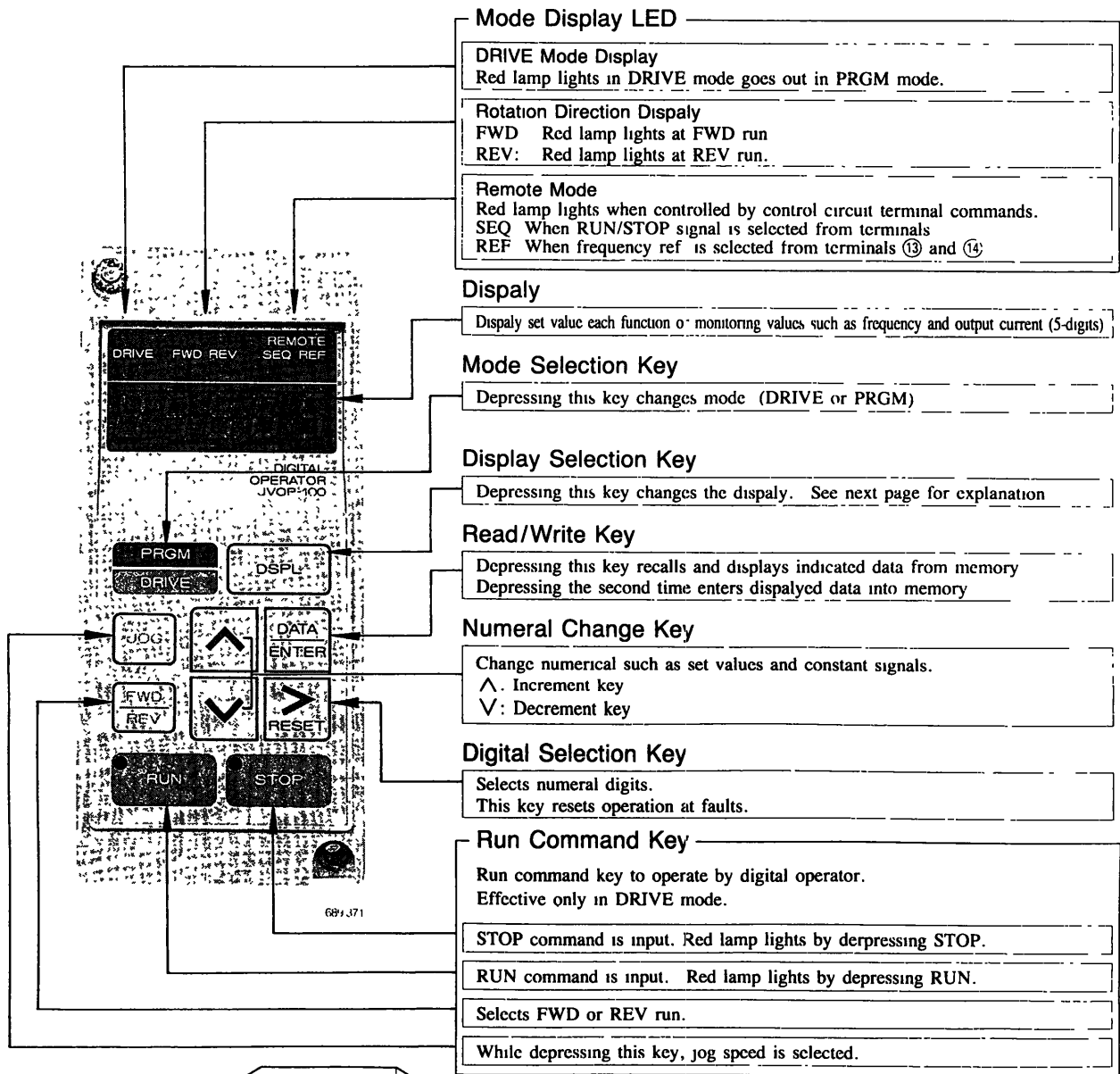

Fig. 5 Line Voltage Jumper

OPERATION

DIGITAL OPERATOR

Digital operator has DRIVE mode and PRGM mode. Selecting DRIVE mode enables the inverter to operate. PRGM mode enables the programs to be written-in. DRIVE and PRGM modes can be switched by  key only when stopped.



RUN or STOP lamp changes in accordance with the following operations.

DRIVE MODE AND PRGM MODE

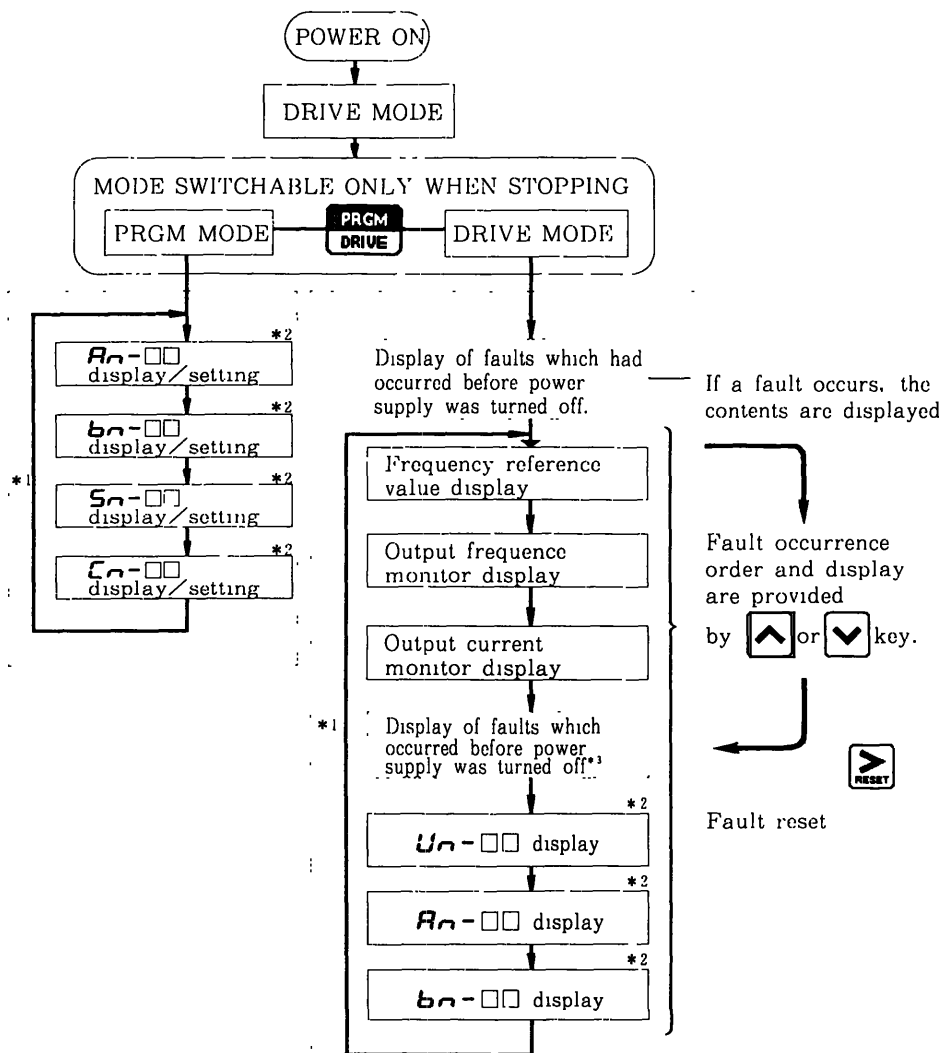

- *1: The constant group to be displayed is changed each time display selection key **DSPL** is depressed.
- *2: For details of constants (An-□□, bn-□□, Cn-□□, Sn-□□, Un-□□), refer to "BASIC CONSTANTS" on page 22.
- *3: Faults that occurred in the previous operation are displayed. Even if the power supply is turned OFF at fault occurrence, the constants are stored so that they are displayed after the power supply is turned ON again. (When no fault occurred, fault display of the previous operation is skipped.)

■ DRIVE MODE

Monitor item is changed each time the display key **DSPL** is depressed. At fault occurrence, the digital operator displays the fault.

Depressing **RESET** key changes to the display immediately before the fault occurred.

Description	Key Operation	Digital Operator Display	Remarks
Drive mode selected	PRGM DRIVE	LED DRIVE Lights	No display when no fault occurred before power supply was turned OFF.
Display of faults which occurred before power supply was turned OFF			
Frequency reference value display/setting	DSPL	F00.00	
Output frequency monitor display	DSPL	0.00	
Output current monitor display	DSPL	0.0A	
Display of faults which occurred before power supply was turned OFF.	DSPL	U1U1	Example Main circuit undervoltage trip
Un- *	DSPL	Un-01	Monitor value is displayed by DATA ENTER Key.
An- *	DSPL	An-01	
bn- *	DSPL	bn-01	

*: Check the display data referring to "BASIC CONSTANTS" on page 22.

■ PRGM MODE

Monitor item is changed each time the **DSPL** key is depressed.

Description	Key Operation	Digital Operator Display	Remarks
PRGM mode selected		<i>An-01</i>	LED OFF
<i>An-</i>	DSPL	<i>An-01</i>	Data is displayed by
<i>bn-</i>	DSPL	<i>bn-01</i>	
<i>sn-</i>	DSPL	<i>sn-01</i>	
<i>cn-</i>	DSPL	<i>cn-01</i>	

*: Check the display data referring to 'BASIC CONSTANTS' on page 22.

[Example: Change Accel Time Setting]

Accel time can be set in either the DRIVE or PRGM mode.

Accel Time Setting	Key Operation	Digital Operator Display	Remarks
• Select accel time constant		<i>bn-01</i>	10 sec is factory setting.
• Display accel time data		<i>10.0</i>	
• Set accel time to 12.5 seconds.		<i>12.5</i>	
• Write-in data.		<i>End</i>	

BASIC CONSTANTS

The constants described here are those required for basic operation. Consult the JVOP-100 digital operator manual for a complete list of constants.

■ *Un-* (Monitor Type)

No.	Item	Display	Unit
<i>Un-01</i>	Frequency reference	120.00	Hz
<i>Un-02</i>	Output frequency	120.00	Hz
<i>Un-03</i>	Output current	4.8A	A
<i>Un-04</i>	Voltage reference	200V	V
<i>Un-05</i>	DC voltage (V.P-N)	Pn270	V
<i>Un-06</i>	Output power/(" " displayed at regeneration)	0.75	kW

■ *Rn-* (Frequency References)

No.	Item	Display	Unit
<i>Rn-01</i>	Master frequency	120.00	Hz
<i>Rn-09</i>	Jog frequency	6.00	Hz

■ *bn-* (Constants to be Changed during Operation)

No.	Item	Display	Unit
<i>bn-01</i>	Acceleration time	10.0	sec
<i>bn-02</i>	Deceleration time	10.0	sec
<i>bn-11</i>	Analog output gain	1.000	—

■ *Sn-* (System Constants to be Changed at Stopping)

No.	Operation Conditions	Data (digits)				Setting prior to Shipment	
		1	2	3	4		
<i>Sn-04</i>	RUN MODE	Master frequency reference: Control terminal 13 or 14 input	—	—	—	0	0011
		Master frequency reference: Digital operator <i>Rn-01</i>	—	—	—	1	
		Operated by control terminal run command.	—	—	0	—	
		Operated by run command from the digital operator.	—	—	1	—	
	STOP MODE	Frequency deceleration to stop	0	0	—	—	
		Coasting to stop	0	1	—	—	
		Full range DC injection braking to stop	1	0	—	—	
		Coasting to stop (restart possible after the time set <i>bn-02</i>)	1	1	—	—	

■ *Cn-* (Control Constants to be Changed at Stopping)

No.	Item	Display	Unit
<i>Cn-09</i>	Motor rated current (to agree with mo/or NP)	3.3	A
<i>Cn-11</i>	DC injection braking current	50	%
<i>Cn-12</i>	DC injection braking time at stop	0.5	sec
<i>Cn-14</i>	Frequency reference (upper limit)	100	%
<i>Cn-15</i>	Frequency reference (lower limit)	12	%
<i>Cn-36</i>	No. of retry operations at fault	5	times

INPUT VOLTAGE SETTING

Set the input power supply voltage to be used, by using the digital operator.
The factory set for 230V class is 200V, and for the 460V class is 400V.

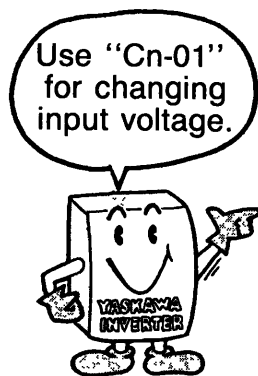

Input Voltage Setting Method	Key Operation	Digital Operator Display	Remarks
POWER ON			
Frequency reference value is displayed		F00.00	
Change mode to PRGM.	PRGM DRIVE	Pr-01	LED DRIVE OFF
Select Cn-01	DSPL Depress three times	Cn-01	
Display data Set to 220V.	DATA ENTER	200.0	
Change set value.	RESET ▲ ▼	220.0	
Write-in new set value	DATA ENTER	End	Displayed for 0.5 second
Switch to DRIVE mode.	PRGM DRIVE	F00.00	LED DRIVE lights

DIGITAL OPERATOR OPERATION

The following diagram shows a typical digital operator operation sequence.

■ OPERATION SEQUENCE

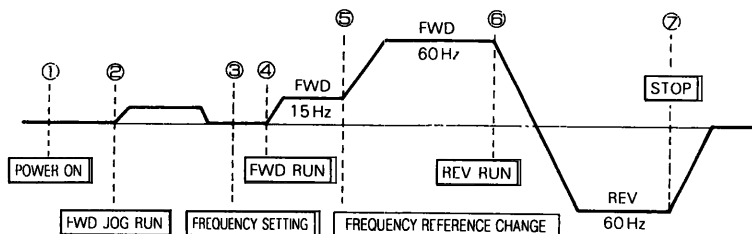

■ TYPICAL OPERATION

Description	Key operation	Digital Operator Display	Remarks
① POWER ON · Frequency reference value is displayed		F00.00	
· Select output frequency monitor display · Check rotation direction (FWD at power ON.)	DSPL	0.00	LED FWD lights.
② FWD JOG RUN · Jog run operation [Activated while key is depressed] 6 Hz	JOG	6.00	
Cont'd			

Description	Key Operation	Digital Operator Display	Remarks
Cont'd			
<p>③ Frequency setting</p> <p>15 Hz</p> <ul style="list-style-type: none"> Select frequency reference value display. Change reference setting Write-in set value Select output frequency monitor display. 	<p>DSPL</p> <p>Depress three times</p> <p>> RESET ▲ ▼</p> <p>DATA ENTER</p> <p>DSPL</p>	<p>F00.00</p> <p>F 15.00</p> <p>F 15.00</p> <p>0.00</p>	<p>Stops blinking for 2 seconds</p>
<p>④ FWD run</p> <p>15 Hz</p> <ul style="list-style-type: none"> FWD run operation 	<p>RUN</p>	<p>15.00</p>	<p>LED run lights.</p>
<p>⑤ Frequency set value change</p> <p>60 Hz</p> <ul style="list-style-type: none"> Select frequency reference Change set value. Write-in set value. Select output frequency monitor display. 	<p>DSPL</p> <p>Depress six times</p> <p>> RESET ▲ ▼</p> <p>DATA ENTER</p> <p>DSPL</p>	<p>F 15.00</p> <p>F60.00</p> <p>F60.00</p> <p>60.00</p>	<p>FWD run (60Hz)</p> <p>Stops blinking for 2 seconds</p>
<p>⑥ REV run</p> <p>60 Hz</p> <ul style="list-style-type: none"> Switch to REV run 	<p>FWD REV</p>	<p>-60.00</p>	<p>REV run (60Hz)</p> <p>LED REV lights.</p>
<p>⑦ Stop</p> <ul style="list-style-type: none"> Deceleration to a stop. 	<p>STOP</p>	<p>0.00</p>	<p>LED stop lights.</p> <p>(LED stop blinks during deceleration.)</p>

CONTROL TERMINAL OPERATION

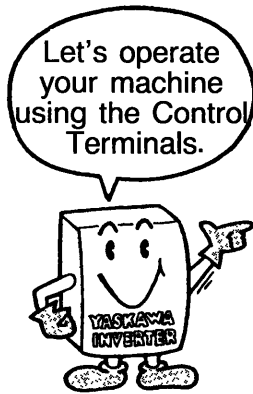

Description	Key Operation	Digital Operator Display	Remarks
<p>POWER ON</p> <ul style="list-style-type: none"> Frequency reference value displayed Select PRGM mode 		<p>F00 00</p> <p>An-01</p>	<p>LED DRIVE OFF.</p>
<p>OPERATION CONDITIONS SET</p> <ul style="list-style-type: none"> displayed Set . Data displayed. Set data to 0000. 	<p></p> <p>Depress twice.</p> <p> </p> <p></p> <p> </p>	<p>Sn-01</p> <p>Sn-04</p> <p>00 11</p> <p>0000</p>	
<p>SET VALUE WRITE-IN</p> <ul style="list-style-type: none"> Check for "End" display. (Operation by control terminal signal enables.) 	<p></p>	<p>End</p>	<p>Displayed for 0.5 second</p>
<p>DRIVE MODE SELECTION</p> <ul style="list-style-type: none"> Change to DRIVE mode. 	<p></p>	<p>F00 00</p>	<p>LED DRIVE lights.</p>
<p>FREQUENCY SET</p> <ul style="list-style-type: none"> Input external voltage (current) into control terminal 13 (14). Check frequency reference on the digital operator. 		<p>F60 00</p>	
<p>OUTPUT FREQUENCY DISPLAY</p> <ul style="list-style-type: none"> Change to output frequency display. 	<p></p>	<p>0. 00</p>	
<p>OPERATION CHECK</p> <ul style="list-style-type: none"> Close between terminals 1 and 11 and terminals 7 and 11 to perform jog operation. 		<p>6. 00</p>	<p>LED lights</p>
<p>RUN</p> <ul style="list-style-type: none"> After checking for normal operation, close between terminals 7 and 11. 		<p>60. 00</p>	<p>Increased to 60 Hz</p> <p>LED lights</p>
<p>STOP</p> <ul style="list-style-type: none"> Open between terminals 1 and 11 to stop 		<p>0 00</p>	<p>Decreased to 0 Hz</p> <p>LED lights</p> <p>LED blinks during deceleration</p>

MAINTENANCE

PERIODIC INSPECTION

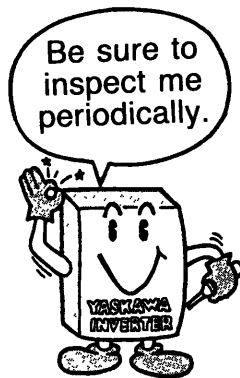

The VS-616G3 requires very few routine checks. It will function longer if it is kept clean, cool and dry, while observing the precautions listed on Page 8 under "LOCATION". Check for tightness of electrical connections, discoloration or other signs of overheating or aging. Use Table 5 as your inspection guide. Before servicing, turn off AC main circuit power and be sure that the CHARGE lamp is OFF.

Table 5 Periodical Inspection

Component	Check	Corrective Action
External terminals, unit mounting bolts, connectors, etc.	Loose screws	Tighten
	Loose connectors	Tighten
Cooling fins	Build-up of dust and dirt	Blow with dry compressed air of 39.2×10^4 to 58.8×10^4 Pa (57 to 85 psi) pressure.
Printed circuit board	Accumulation of conductive dust or oil.	Blow with dry compressed air of 39.2×10^4 to 58.8×10^4 Pa (57 to 85 psi) pressure. If dust and oil cannot be removed, replace the board.
Cooling fan	For abnormal noise and vibration. Whether the cumulative operation time exceeds 20,000 hours or not.	Replace the cooling fan.
Power elements	Accumulation of dust and dirt	Blow with dry compressed air of 39.2×10^4 to 58.8×10^4 Pa (57 to 85 psi) pressure.
Smoothing capacitor	Discoloration or odor	Replace the capacitor or inverter unit.

Note: Operating conditions are as follows:

- Ambient temperature : 30°C (86°F)/yearly average
- Load factor : 80% or below
- Operation rate : 12 hours or below / day

FAULT DISPLAY

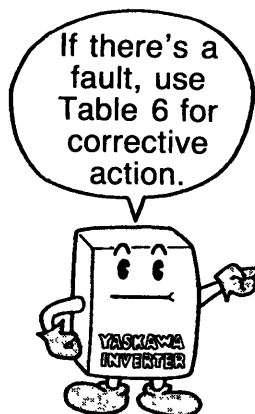

As Table 6 shows, the faults that the VS-616G3 detects are classified into troubles and alarms. If a problem occurs, the fault contact is output and the motor coasts to a stop. When an alarm is issued, the digital operator indicates the alarm for warning.

Table 6 Fault Display and Details

Indication	Fault Display	Description	Corrective Action
<i>Uu1</i>	Undervoltage (PUV)	Low main power circuit voltage during operation.	<ul style="list-style-type: none"> • Check wiring. (at power supply side) • Correct power supply voltage.
<i>Uu2</i>	Undervoltage (CUV)	Low control circuit voltage during operation.	
<i>Uu3</i>	Undervoltage (MC-ANS fault)	Main circuit magnetic contactor does not operate correctly.	
<i>GF</i>	Grounding	Grounding current > approx. 50% of inverter rated current	<ul style="list-style-type: none"> • Check that motor insulation has not deteriorated. • Check that there is no damage to wiring at load side.
<i>oC</i>	Overcurrent	Inv. output current > 200% of Inv. rated current	<ul style="list-style-type: none"> • Check the motor winding resistance and ground. • Increase accel time.
<i>ov</i>	Overvoltage	Detection level: Approx. 400V for 200V class Approx. 800V for 400V class [(Cn-01) ≥ 400V] Approx. 700V for 400V class [(Cn-01) < 400V]	Increase decel time and/or add braking resistor.
<i>FU</i>	Fuse blown	—	Check short-circuit at load, ground fault etc.
<i>oH</i>	Radiation fin overheated	Fin temperature 90°C (194°F)	Check fan or ambient temperature (less than 45°C, 113°F).
<i>oL1</i>	Overload	Protect the motor.	Measure motor temperature-rise and reduce load, then reset V/f.
<i>oL2</i>	Overload	Protect the inverter.	Reduce load, and increase accel time, then reset V/f.
<i>oL3</i>	Overtorque	When selecting inv. output OFF at "inv. output current > over-torque detection level" and over-torque detection.	—
<i>rr</i>	Regenerative transistor fault	—	Replace transistor.
<i>rH</i>	Braking resistor overheated	Protect braking resistor incorporated in inverter unit.	Reduce regenerative load, or use other resistor unit separately installed.
<i>FAn</i>	Cooling fan fault	Cooling fan stops during operation	Replace cooling fan.
<i>EF3</i>	Control circuit terminal ③ fault	Stop mode selection possible	Check state of input terminal with data Un-07 <i>Un-07</i> { Replace inverter if "!" is indicated as the state of open terminal. }
<i>EF5</i>	Control circuit terminal ⑤ fault		
<i>EF6</i>	Control circuit terminal ⑥ fault		
<i>EF7</i>	Control circuit terminal ⑦ fault		
<i>EF8</i>	Control circuit terminal ⑧ fault		

Table 6 Fault Display and Details (Cont'd)

Indication	Fault Display	Description	Corrective Action
<i>bUS</i>	Communication inverter card (option) communication error	Stop mode selection possible	Check communication cable between communication interface card (SI-B) and master controller.
<i>CPF00</i>	Operator communication error	Communication between G3 and operator is not established 5 seconds after the power supply is turned ON.	<ul style="list-style-type: none"> • Insert operator connector plug again. • Replace control board. • Check wiring of control board.
<i>CPF01</i>	Operator communication error	Communication error occurs for 2 seconds after communication between G3 and operator is once established after the power supply is turned ON.	<ul style="list-style-type: none"> • Insert operator connector plug again. • Replace control board.
<i>CPF02</i>	Control circuit fault	Inverter fault	• Replace control PC board.
<i>CPF03</i>	NV-RAM (S-RAM) fault		
<i>CPF04</i>	NV-RAM (BCC, Access Code) fault		
<i>CPF05</i>	A/D converter fault in CPU		
<i>CPF06</i>	Optional connection fault	—	• Check and secure the option card connector.
<i>CPF20</i>	Fault of A/D converter in analog speed reference card (option)	Option card fault	Replace option card.
<i>CPF21</i>	Self-analysis fault of CP-213 communication interface card (option)		
<i>CPF22</i>	Model code fault of CP-213 communication interface card (option)		
<i>CPF23</i>	Mutual analysis fault of CP-213 communication interface card (option)		

CAUTION

If “FU” fault occurs, check the output transistors first, before replacing the DC bus fuse.

APPENDIX B

DIMENSIONS in inch (mm)

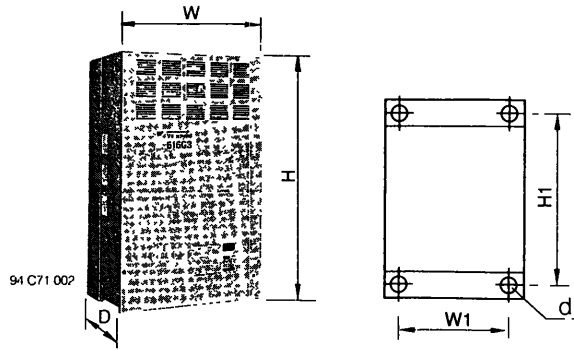

Voltage V	Motor Output HP (kW)	VS616G3													
		Open Chassis Type							Enclosed Type						
		W	H	D	W1	H1	Mtg. Hole d	Mass lb (kg)	W	H	D	W1	H1	Mtg. Hole d	Mass lb (kg)
200 to 230	40 (30)	To be released shortly.													
	50 (37)														
	60 (45)														
	75 (55)														
380 to 460	100 (75)	17.91 (455)	32.28 (820)	12.99 (330)	13.78 (350)	31.30 (795)	M10	190 (86)	18.11 (460)	44.49 (1130)	12.99 (330)	13.78 (350)	31.30 (795)	M10	203 (92)
	150 (110)	22.64 (575)	36.42 (925)	13.98 (355)	17.52 (445)	35.24 (895)	M12	291 (132)	22.84 (580)	50.79 (1290)	13.98 (355)	17.52 (445)	35.24 (895)	M12	315 (143)
	200 (160)	22.64 (575)	36.42 (925)	14.96 (380)	17.52 (445)	35.24 (895)	M12	291 (146)	22.84 (580)	50.79 (1290)	14.96 (380)	17.52 (445)	35.24 (895)	M12	346 (157)
	75 (55)	17.91 (455)	32.28 (820)	12.99 (330)	13.78 (350)	31.30 (795)	M10	190 (86)	18.11 (460)	44.49 (1130)	12.99 (330)	13.78 (350)	31.30 (795)	M10	203 (92)

Note: For detailed dimensions, contact your YASKAWA Representative.

APPENDIX C

V/f PATTERN (Sn-02)

The following V/f patterns can be selected by Sn-02. Set inverter input voltage to Cn-01 before V/f pattern selection.

- Sn-02 data ① to ⑤ : Impossible to change
- Sn-02 data ⑥ : Possible to set freely (The following shows the data after initialization.)

■ 40HP (30kW) to 60HP (45kW) V/f PATTERN SELECTION (230V Class)

Application	Specification	Sn-02	V/f Pattern	Application	Specification	Sn-02	V/f Pattern		
General Purpose	50Hz	①		High Starting Torque	50Hz	Low Starting Torque			
						High Starting Torque		⑨	
	60Hz	60Hz Saturation	① ⑥			60Hz	Low Starting Torque	① ⑥	
		50Hz Saturation	②				High Starting Torque	②	
	72Hz	③			90Hz	③			
Variable Torque Operation (Fans and Pumps)	50Hz	Variable Torque 1		Constant HP Operation (Machine Tools)	120Hz	④			
		Variable Torque 2						⑤	
	60Hz	Variable Torque 1			180Hz	⑤			
		Variable Torque 2						⑦	

■ 75HP (55kW) to 200HP (160kW) V/f PATTERN SELECTION (230V Class*)

Application	Specification	Sn-02	V/f Pattern	Application	Specification	Sn-02	V/f Pattern	
General Purpose	50Hz	①		High Starting Torque (Note 2)	50Hz	⑧		
	60Hz	60Hz Saturation	① ②			50Hz	⑨	
		50Hz Saturation	②			60Hz	⑩	
	72Hz	③			90Hz	⑪		
Variable Torque Operation (Fans and Pumps)	50Hz	Variable Torque 1	④	Constant HP Operation (Machine Tools)	120Hz	⑫		
		Variable Torque 2	⑤					
	60Hz	Variable Torque 1	⑥		180Hz	⑬		
		Variable Torque 2	⑦					

* Voltage values are doubled for 460V class.
 150 to 200HP (110 to 160kW) for only 460V class.

- Notes: 1. Consider the following points as V/f pattern selecting conditions.
 (1) Select a pattern in accordance with the motor voltage-frequency characteristics.
 (2) Select a pattern in accordance with the motor maximum r/min.
2. High starting torque should be selected only in the following cases:
 (1) Wiring distance is long (approx. 492ft 150m or more).
 (2) Voltage drop at start is large.
 (3) AC reactor is inserted in the inverters input or output circuit.
 (4) The motor is smaller than the maximum applicable motor.

APPENDIX D

TYPICAL CONNECTION DIAGRAM

(1) Braking Unit (3 in parallel)
 For Models CIMR-G3□2L30 to -G3□2L75
 (230V Class, 40 to 100HP, 30 to 75kW)

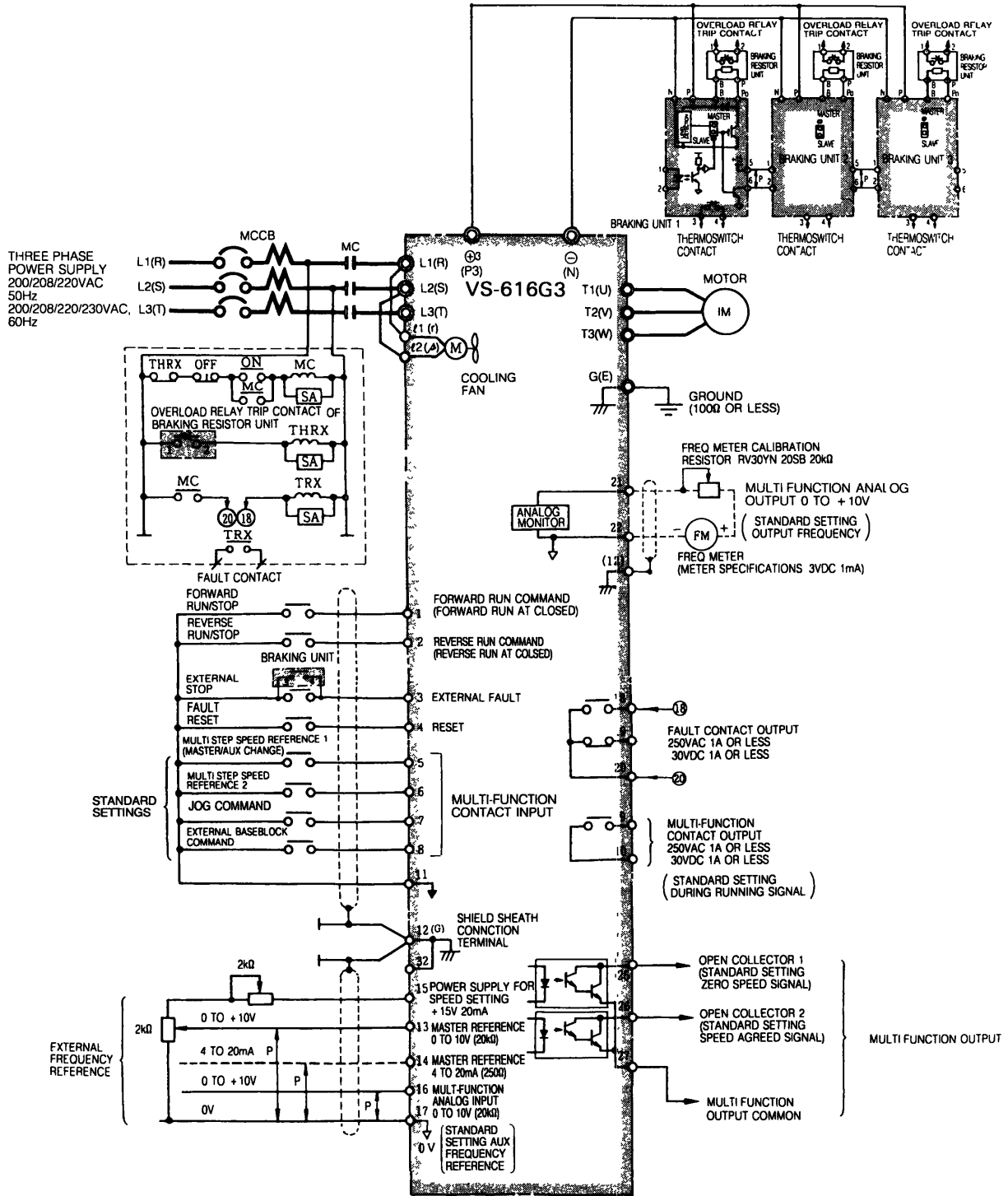

For Models CIMR-G3□4L55 to -G3□4LA6
(460V Class, 75 to 200HP, 55 to 160kW)

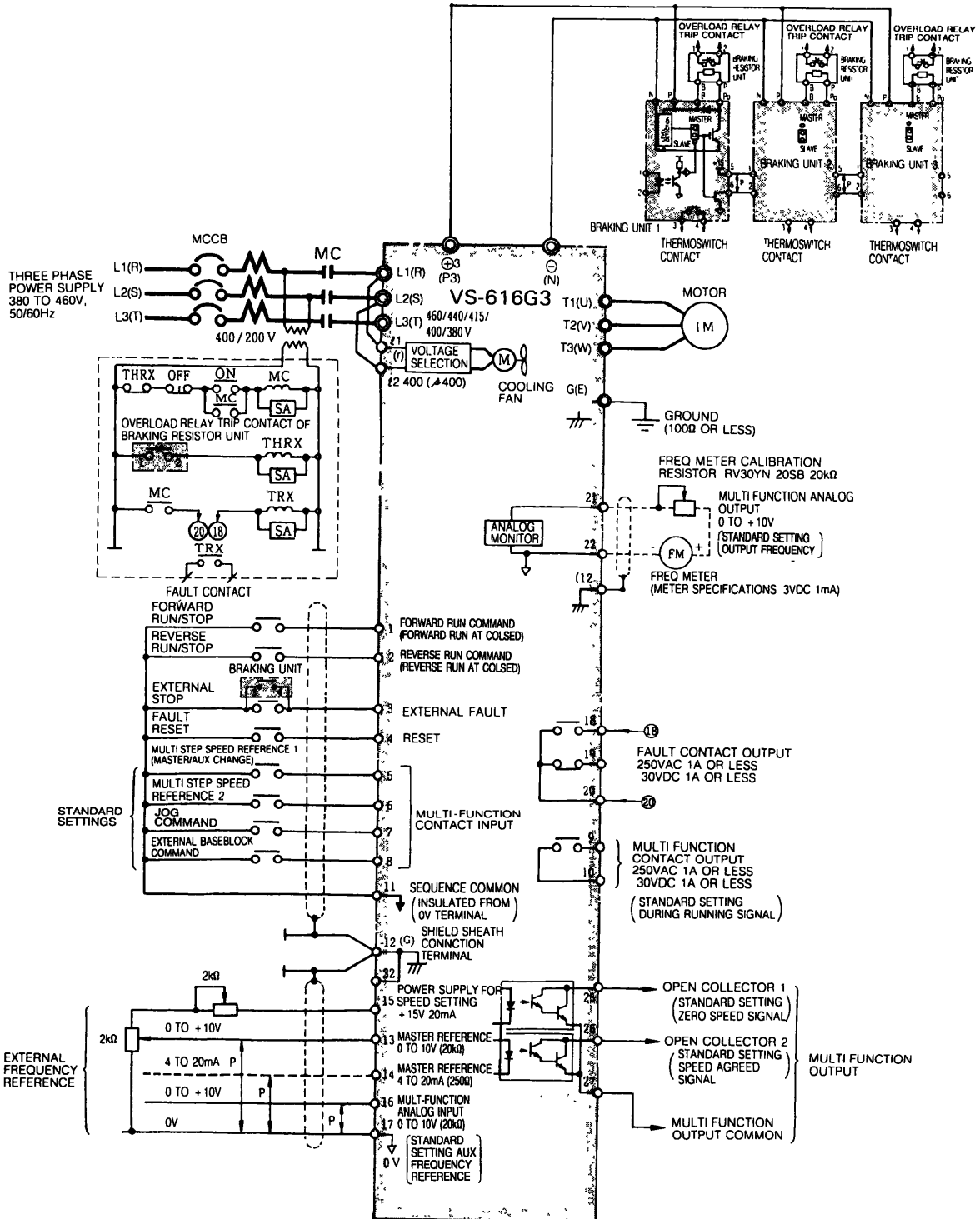

TYPICAL CONNECTION DIAGRAM

(2) Run/Stop by Main Circuit Magnetic Contactor
 For Model CIMR-G3□2L30 (230V Class, 40HP, 30kW)

Turn on the power supply after checking that the motor has stopped. This circuit cannot be used for an application with a duty cycle of 1 hour or less.

System Constant Setting

System Constant No.	Data			
	4th digit	3rd digit	2nd digit	1st digit
Sr-04	-	1	0	1*
Sr-11	-	1	-	-

* Frequency reference setting
 0: Set by control circuit terminal
 1: Digital operator set value (An-01)

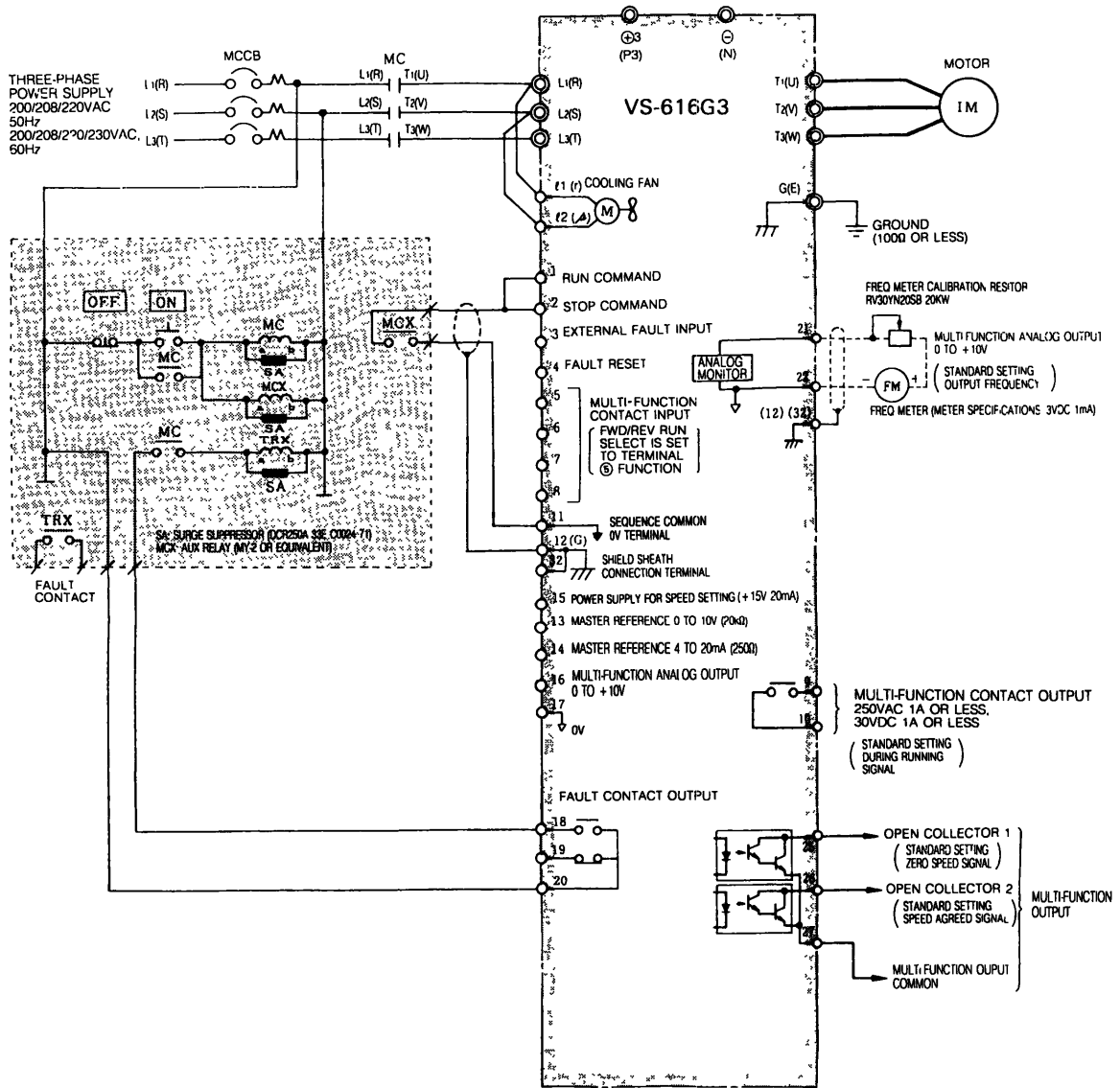

- Notes:
1. Braking is not activated at deceleration stop. It coasts to a stop.
 2. Use MC or MCX of delay release type for restart operation after momentary power loss.
 3. Frequency setting resistor is not required for the use of digital operator's set value as frequency reference.

(3) With VS Operator Model JVOP - 95 • □

System Constant Setting

System Constant No.	Data			
	4th digit	3rd digit	2nd digit	1st digit
S _n -04	—	—	0	0
S _n -05	0	—	0	—
S _n -15	—	—	0	3
S _n -19	—	—	0	0*
S _n -20	—	—	0	0

* Connect to control circuit terminal 13 or 16 according to the application. For terminal 16, set S_n-19 = × × 00.

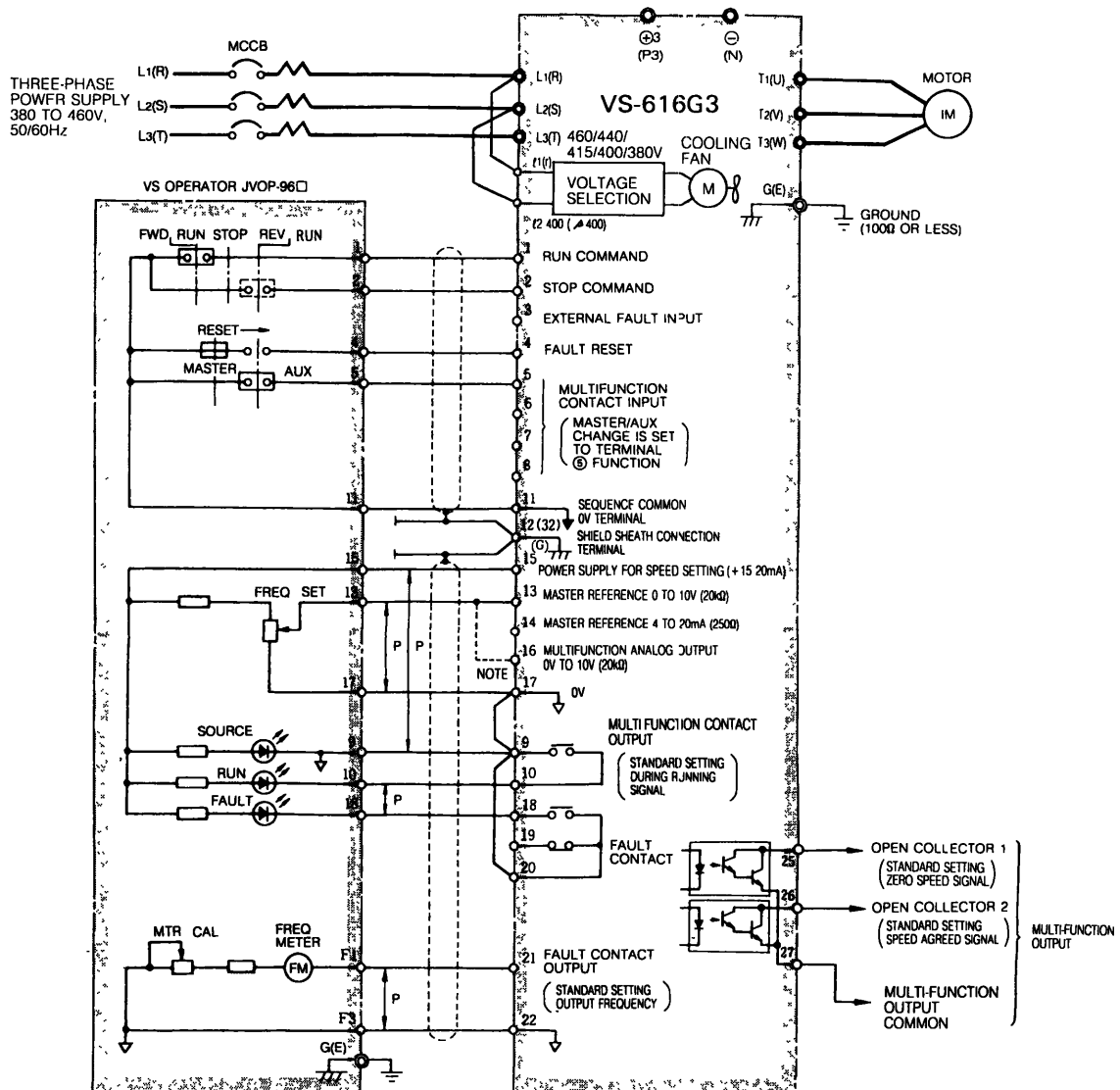

TYPICAL CONNECTION DIAGRAM

(4) With VS Operator Model JVOP - 96 • □

System Constant Setting

System Constant No.	Data			
	4th digit	3rd digit	2nd digit	1st digit
S _n -04	—	—	0	0
S _n -05	0	—	0	—
S _n -15	—	—	0	3
S _n -19	—	—	0	0*
S _n -20	—	—	0	0

* Connect to control circuit terminal 13 or 16 according to the application. For terminal 16, set S_n-19 = × × 00.

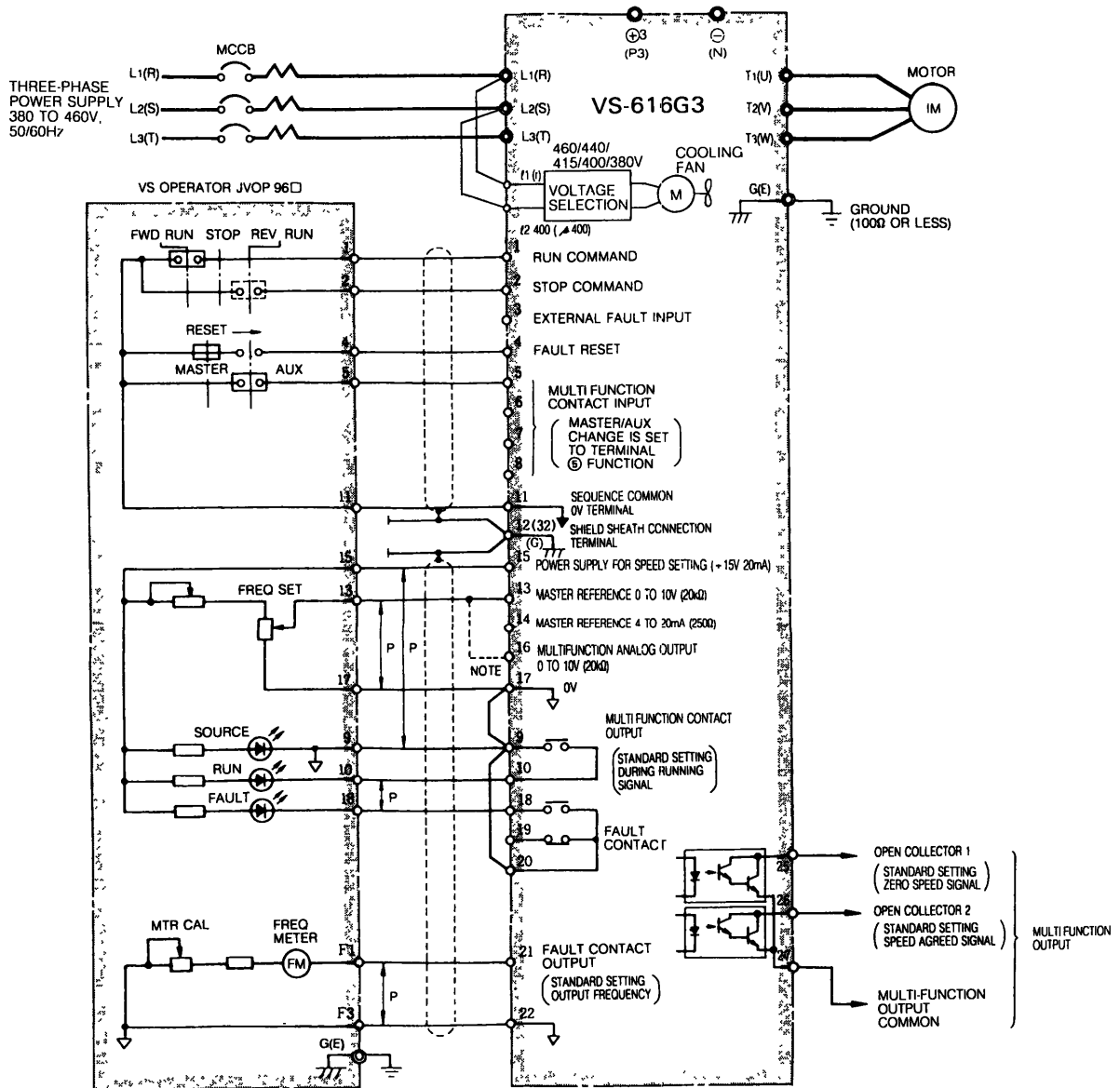

(5) With Transistor Open Collector for Operation Signal

System Constant Setting

System Constant No.	Data			
	4th digit	3rd digit	2nd digit	1st digit
50-04	-	-	0	0

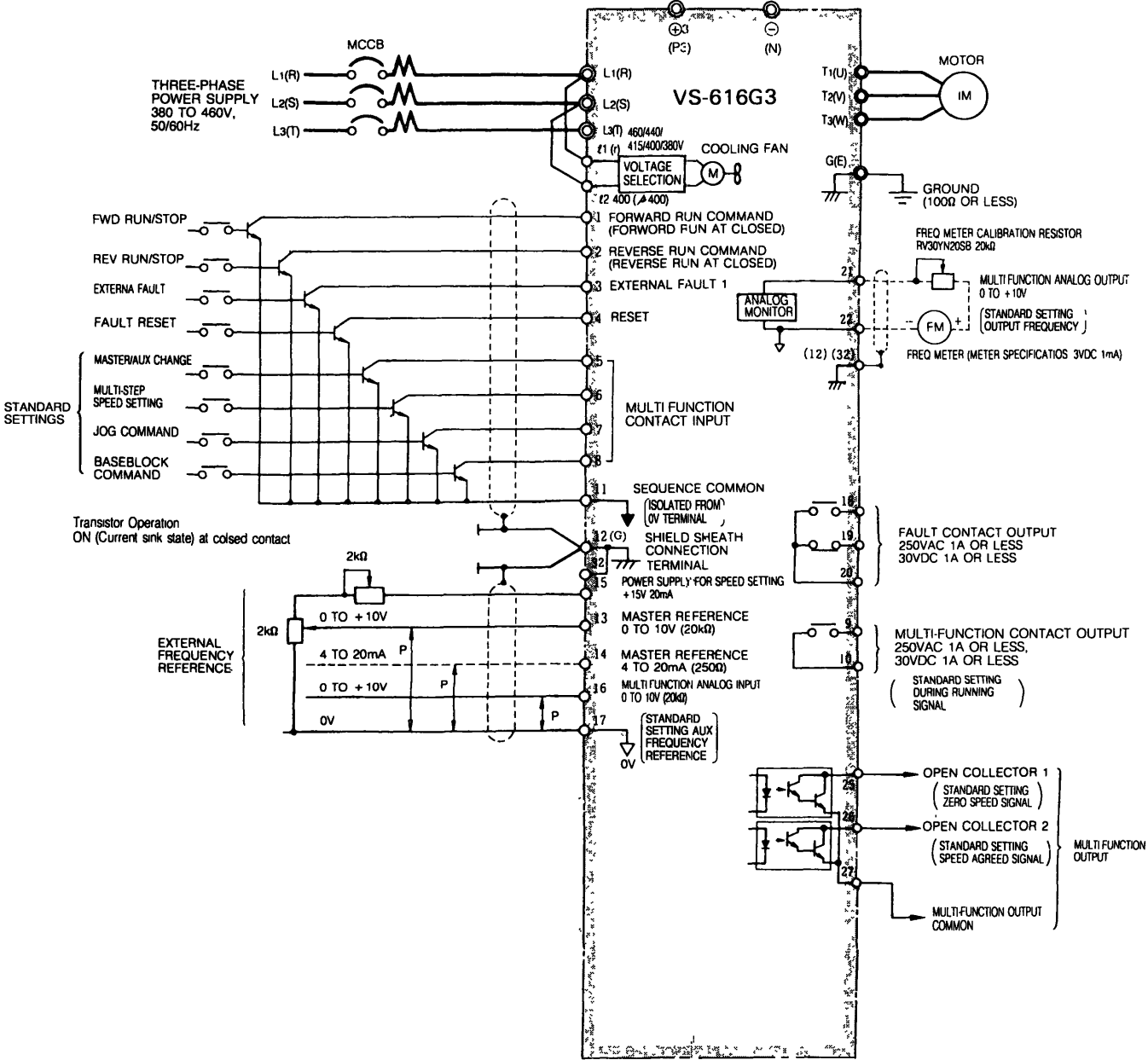

TYPICAL CONNECTION DIAGRAM

(6) With Contact Output, Photo-coupler Output

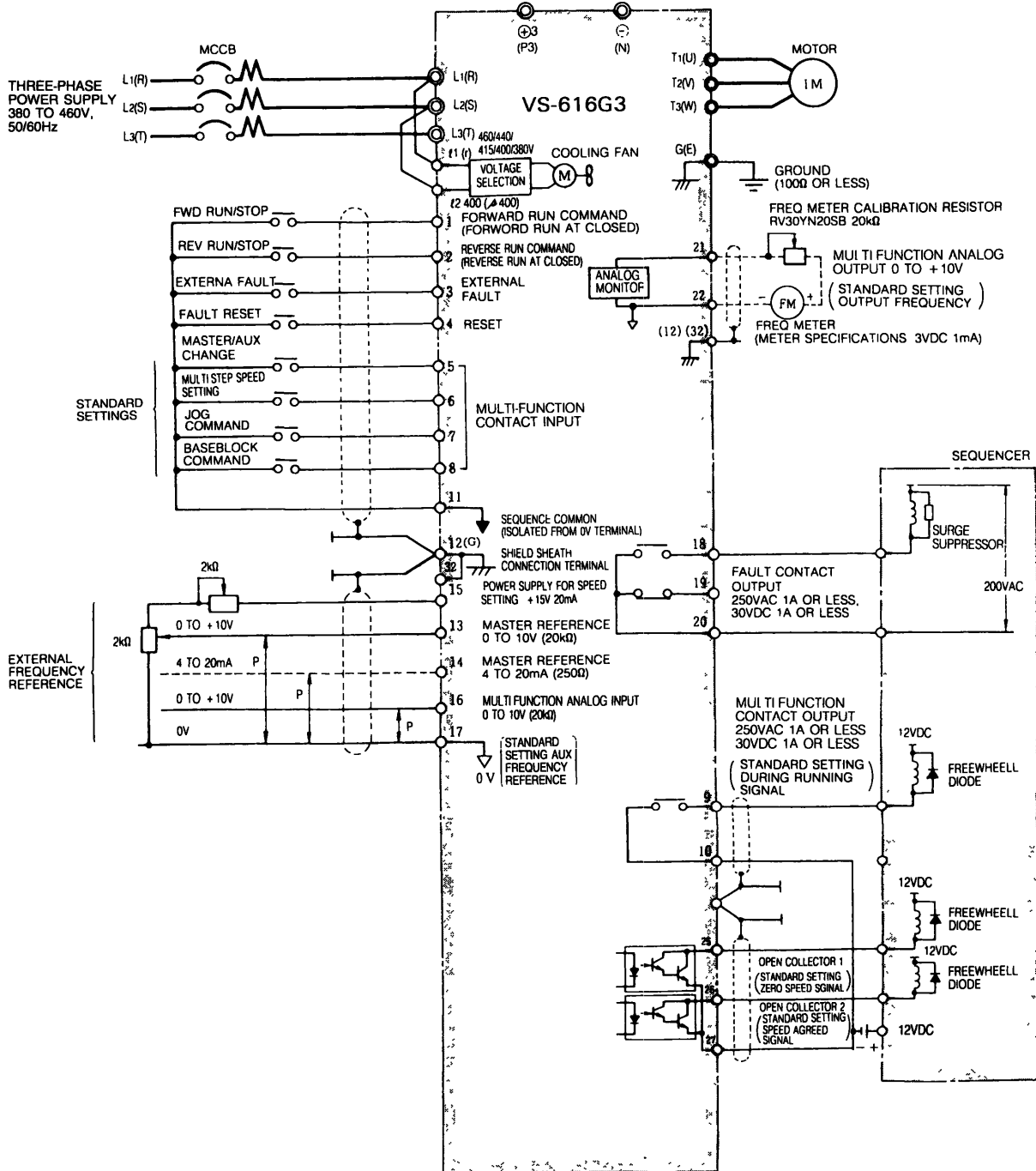

(1) OPTION CARDS (Cont'd)

(Except digital output card DO-08, these terminals are to be connected only class 2 circuits)

Name	Code No.	Function	Installing Position	Document No.
PG Speed Control Card		Used to compensate for speed fluctuations due to slip, utilizing a motor PG (pulse generator) which provides a means of speed feedback.		
PG-C	73600-D005X	<ul style="list-style-type: none"> • For single-ended push-pull input or open collector input • Phase A (single phase) input • PG frequency range: 50 to 32767 Hz • Pulse monitor output: +12V, 20 mA • Input voltage: +12 V • Input current: 300 mA } External power supply required	Attach the card at 3CN on the control circuit board. (See Note 2)	TOE-C736-30.3
PG-D	73600-D006X	<ul style="list-style-type: none"> • For differential input • Phase A (differential pulse) input • PG frequency range: 50 to 32767 Hz • I/O standard is in compliance with RS-422A. • Input voltage: +12 V • Input current: 300 mA } External power supply required		

- Notes
- 1 Only one option card can be installed at 2CN at a time.
 - 2 Only one option card can be installed at 3CN at a time.
 3. When a communication interface card is attached at 2CN, no option card can be attached at 3CN.
 - 4 All option card terminals (except digital output card DO-08) should be connected to class 2 circuits

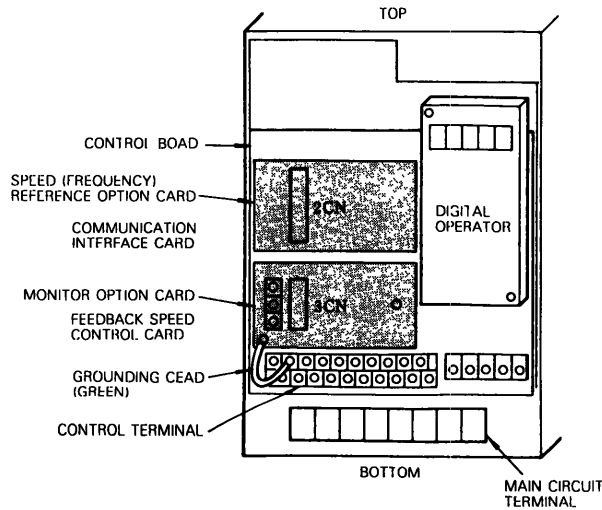

Option Card Installing Position

(2) OPTION UNITS

Name	Model (Code No.)	Function	Installing Position	Document No.
Digital Monitor	JVOP - 101 (73041 - 0911X)	Permits display of frequency and current by digital monitor and indication of a problem. Not equipped with key pads for RUN/STOP operation and setting a constant so that it can be safely used at the site.	On the inverter *1	TOE- C730-50.4
Remote Operator	JVOP - 102 (73041 - 0912X)	Digital operator (JVOP-100) and digital monitor (JVOP-101) are built-in. Can perform operation or monitoring by serial communication at a distance of 328ft (100m) maximum from the inverter. 200mA current 100P Power supply: 85 to 264VAC, 50 to 60Hz (D-SUB connector, cover, power supply connector provided)	Separately-mounted For open chassis or enclosed type	TOE- C736-20.4
Remote Monitor	JVOP - 103 (73041 - 0913X)			
Remote Interface	JVOP - 104 (73041 - 0914X)	Mounted on the inverter for remote operation or monitoring [up to 328ft (100m)] by remote operator (JVOP-102) or remote monitor (JVOP-103). 20mA current 100P/RS-232C (D-SUB connector, cover provided)	On the inverter	
Operator/Monitor Adapter	JVOP - 109 (73041 - 0919X)	This removable adapter panel can be used on the inverter cover with an extension cable when the digital operator or digital monitor needs to be removed from the inverter cover.	On the inverter *1	TOE- C736-50.11
Adapter Panel Exclusive Use Extension Cable	3.3ft (1m) cable (72616-W3001-01) 9.9ft (3m) cable (72616-W3003-01)	Used for remote mounting of the digital operator/monitor using adapter panel (JVOP-109)	—	
VS Operator (Small Plastic Version)	JVOP - 95* [] (73041 - 0905X - [])	An exclusive control panel for remotely setting frequency and for starting and stopping an inverter using analog commands [distance up to 164ft (50m)]. Scale on the frequency indicator: 60/120Hz, 90/180Hz	Separately installed	—
VS Operator (Standard Version)	JVOP - 95* [] (73041 - 0905X* [])	An exclusive control panel for remotely setting frequency and for starting and stopping an inverter using analog commands [distance up to 164ft (50m)]. Scale on the frequency indicator, 75Hz, 150Hz, 220Hz	Separately installed	—
Extension *1 Cable for Digital Operator or Monitor	3.3ft (1m) cable (72616 - W3001) 9.9ft (3m) cable (72616 - W3003)	This extension cable is used when the digital operator or digital monitor is used after removing from the inverter front cover. The cable is available in 3.3ft (1m) and 9.9ft (3m) lengths. The package of the extension cable includes a simple indicating cover. Depending on the application, the use of the operator/monitor adapter JVOP-109 is recommended.	On the inverter *1	TOE- C730-50.10

(2) OPTION UNITS (Cont'd)

Name	Model (Code No.)	Function	Installing Position	Document No.
Braking Unit	CDBR - □□ (73600 - R□□□□□□□0)	Used in combination with the braking resistor unit to reduce the motor deceleration time.	Separately installed	TOF- C736-50.5
Braking Resistor Unit	LKEB - □□ (73600 - K□□□□□□□0)	Shortens the motor deceleration time by consuming the regenerative energy through the resistor.	Separately installed	TOE- C736-50.5
Back up Capacitor Unit for Momentary Power Loss	P00□□□ (73600 - P00□□□0)	Designed for momentary power loss of control power. (Backup time: 2sec.)	Separately installed	TOI- C736-50.6
Control Power Unit for DI-16G	AVR387 (72600-AVR387)	Used to supply power to digital reference card (DI-16G). • Input: 200 to 240VAC ±10% 50/60Hz • Output: +24VDC 0.2A	Separately installed	TOE- C736-30.17
	AVR388 (72600-AVR388)	Use AVR388 for momentary power loss. (Backup time: 2sec.)		
Control Power Unit for PG-C	AVR385 (72600-AVR385)	Used to supply power to PG speed control card (PG-C). • Input: 200 to 240VAC ±10% 50/60Hz • Output: +12VDC 0.3A	Separately installed	TOE- C736-30.3
	AVR386 (72600-AVR386)	Use AVR386 for momentary power loss. (Backup time: 2sec.)		

- *1 Only one of the options, JVOP-101 or -109, can be installed at a time
When attaching either option, the digital operator (JVOP-100, provided as a standard feature) must be removed
- *2 The type of frequency indicator is to be shown in the box after the model name and the code number.

In Case of VS Operator

Frequency Indicator (max. scale)	Model	Code No.
60/120/75Hz	1	01
90/180/150Hz	2	02
220Hz	3	03

- *3 Exclusive extension cables with blind cover can not be removed on the inverter front cover.
When digital operator/monitor is operated remotely (3.3ft 1m, 9.9ft 3m), use exclusive use extension cable (with indicating cover) or adapter panel and adapter panel exclusive use extension cable.

Varispeed-616G3 INSTRUCTIONS

200 to 230V, 40 to 100HP (30 to 75kW) 54 to 130kVA
380 to 460V, 75 to 200HP (55 to 160kW) 110 to 250kVA

TOKYO OFFICE Ohtemachi Bldg, 1-6-1 Ohtemachi Chiyoda-ku Tokyo 10C Japan
Phone (03) 3284-9111 Telex YASKAWA J33530 Fax (03) 3284-9034

YASKAWA ELECTRIC AMERICA, INC

Chicago-Corporate Headquarters 2942 MacArthur Blvd Northbrook, IL 60062-2028 U S A
Phone (708) 291-2340 Fax (708) 498-2430

Chicago-Technical Center 3160 MacArthur Blvd Northbrook, IL 60062-1917 U S A
Phone (708) 291-0411 Fax (708) 291-1018

MOTOMAN INC

805 Liberty Lane West Carrollton OH 45449, U S A
Phone (513) 847-6200 Fax (513) 847-6277

YASKAWA ELÉTRICO DO BRASIL COMÉRCIO LTDA

Rua Conde Do Pinhal 8-5° Andar Sala 51 CEP 01501-São Paulo-SP Brasil
Phone (011) 35-1911 Fax (011) 37-7375

YASKAWA ELECTRIC EUROPE GmbH

Am Kronberger Hang 2 65824 Schwalbach Germany
Phone (49) 6196-569-300 Fax (49) 6196-888-301

Motoman Robotics AB

Box 130 S-38500 Torsås Sweden
Phone 0486-10575 Fax 0486-11410

Motoman Robotec GmbH

Kammerfeldstraße 1 85391 Ailershausen Germany
Phone 08166-900 Fax 08166-9039

YASKAWA ELECTRIC UK LTD

3 Drum Mains Park Orchardton Woods Cumbernauld, Scotland G68 9LD U K
Phone (236)735000 Fax (236)458182

YASKAWA ELECTRIC KOREA CORPORATION

8th Floor Seoul Center Bldg, 91-1, Sogong-Dong, Chung-ku, Seoul Korea 100-070
Phone (02)776-7844 Fax (02)753-2639

YASKAWA ELECTRIC (SINGAPORE) PTE LTD.

Head Office CPF Bldg, 79 Robinson Road # 13-05, Singapore 0106, SINGAPORE
Phone 221-7530 Telex (87) 24890 YASKAWA RS Fax 224-5854

Service Center 221 Henderson Road, # 07-20 Henderson Building Singapore 0315 SINGAPORE
Phone 276-7407 Fax 276-7406

YATEC ENGINEERING CORPORATION

Shen Hsiang Tang Sung Chiang Building 10F 146 Sung Chiang Road, Taipei Taiwan
Phone (02) 563-0010 Fax (02) 567-4677

SHANGHAI OFFICE Room No 8B Wan Zhong Building 1303 Yan An Road (West), Shanghai 200050, CHINA

Phone (86) 212-1015 Fax (86) 212-1015

TAIPEI OFFICE Shen Hsiang Tang Sung Chiang Building 10F 146 Sung Chiang Road Taipei Taiwan
Phone (02) 563-0010 Fax (02) 567-4677



YASKAWA

YASKAWA ELECTRIC CORPORATION



* T O A - S 6 1 6 - 6 . 5 B *